

## **100GBASE QSFP28 LWDM 1295-1310 20km DDM SMF Transceiver**

### **P/N: AE-QSFP28-LH4**

#### **Features**

- Compliant with 100GBASE-HR4
- Support line rates from 103.125 Gbps to 111.81 Gbps
- Integrated LAN WDM TOSA / PIN ROSA for up to 20 km reach over SMF without FEC
- Digital Diagnostics Monitoring Interface
- Duplex LC optical receptacle
- No external reference clock
- Electrically hot-pluggable
- Compliant with QSFP28 MSA with LC connector
- Case operating temperature range:0°C to 70°C
- Power dissipation < 3.5 W

#### **Applications**

- 100G Ethernet &100GBASE-LR4
- ITU-T OTU4

#### **Description**

AE-QSFP28-LH4 optical Transceiver integrates receiver and transmitter path on one module. In the transmit side, four lanes of serial data streams are recovered, retimed, and passed to four laser drivers. The laser drivers control 4- EML with center wavelength of 1296nm, 1300nm, 1305nm and 1309 nm. The optical

signals are multiplexed to a single –mode fiber through an industry standard LC connector. In the receive side, the four lanes of optical data streams are optically de-multiplexed by the integrated optical de-multiplexer. Each data stream is recovered by a APD and trans-impedance amplifier, retimed. This module features a hot-pluggable electrical interface, low power consumption and MDIO management interface.

The product is designed with form factor, optical/electrical connection and digital diagnostic interface according to the QSFP28 Multi-Source Agreement (MSA) and compliant to IEEE 802.3bm.

## I. Absolute Maximum Ratings

Parameter	Symbol	Min	Typ	Max	Unit	Note
Storage Temperature	Ts	-40	-	85	°C	
Relative Humidity	RH	5	-	95	%	
Power Supply Voltage	VCC	-0.3	-	4	V	
Signal Input Voltage		Vcc-0.3	-	Vcc+0.3	V	

## II. Recommended Operating Conditions

Parameter	Symbol	Min	Typ	Max	Unit	Note
Case Operating Temperature	Tcase	0	-	70	°C	Without air flow
Power Supply Voltage	VCC	3.13	3.3	3.47	V	
Power Supply Current	ICC	-		1120	mA	
Data Rate	BR		25.78125		Gbps	Each channel
Transmission Distance	TD		-	20	km	
Coupled fiber		Single mode fiber				9/125um SMF

Notes : 100G Ethernet and ITU-T OTU4 has different register setting , not auto-Negotiation

## III. Optical Characteristics

Parameter	Symbol	Min	Typ	Max	Unit	Note
Transmitter						
Wavelength Assignment	$\lambda_0$	1294.53	1295.56	1296.59	nm	
	$\lambda_1$	1299.02	1300.05	1301.09	nm	
	$\lambda_2$	1303.54	1304.58	1305.63	nm	
	$\lambda_3$	1308.09	1309.14	1310.19	nm	
Total Output. Power	POUT			10.5	dBm	
Average Launch Power Per lane		-4.3		4.5	dBm	
Spectral Width (-20dB)	$\sigma$			1	nm	
SMSR		30			dB	
Optical Extinction Ratio	ER	4			dB	
Average launch Power off per lane	Poff			-30	dBm	
RIN	RIN			-128	dB/Hz	
Output Eye Mask definition {X1, X2, X3, Y1, Y2, Y3}		{0.25, 0.4, 0.45, 0.25, 0.28, 0.4}				

Receiver						
Receive Power per lane(Max)	Rov			-7	dBm	
Receiver Sensitivity (OMA), each Lane (BER = 5x10 <sup>-5</sup> )				-10.6	dBm	1
Receiver Sensitivity (OMA), each Lane (BER = 1x10 <sup>-12</sup> )				-15	dBm	1
LOS De-Assert	LOSD	-25			dBm	
LOS Assert	LOSA			-13	dBm	

Notes: Measured with a PRBS 231-1 test pattern, @25.78Gb/s

#### IV. Electrical Characteristics

Parameter	Symbol	Min	Typ	Max	Unit	Note
Supply Voltage	Vcc	3.13	3.3	3.47	V	
Supply Current	Icc			1200	mA	
Transmitter						
Input differential impedance	Rin		100		Ω	1
Differential data input swing	Vin,pp	180		1000	mV	
Transmit Disable Voltage	VD	Vcc-1.3		Vcc	V	
Transmit Enable Voltage	VEN	Vee		Vee+ 0.8	V	2
Receiver						
Differential data output swing	Vout,pp	300		850	mV	3
LOS Fault	VLOS fault	Vcc-1.3		VccHOS T	V	4
LOS Normal	VLOS norm	Vee		Vee+0.8	V	4

Notes:

1. Connected directly to TX data input pins. AC coupled thereafter.
2. Or open circuit.
3. Into 100 ohms differential termination.
4. Loss of Signal is LVTTTL. Logic 0 indicates normal operation; logic 1 indicates no signal detected.

#### V. Pin Assignment

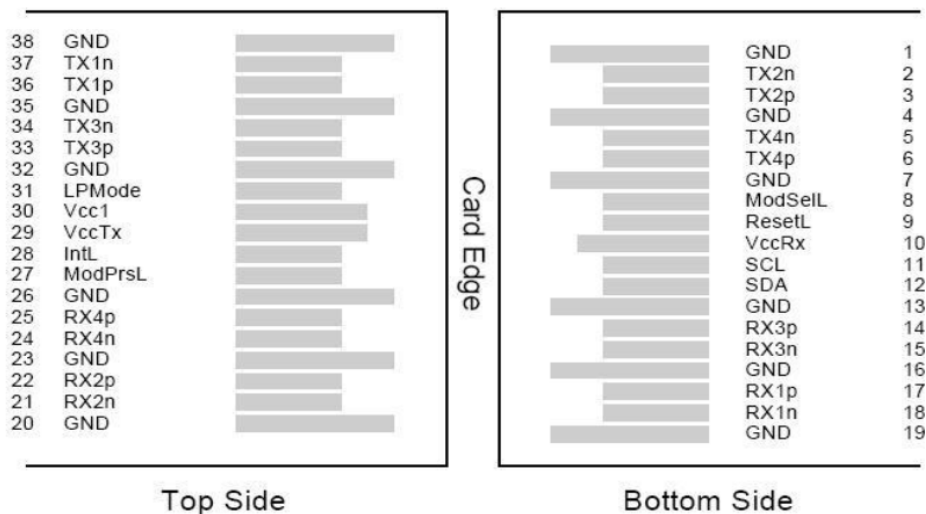

Pin	Symbol	Name/Description	Note
1	GND	Transmitter Ground (Common with Receiver Ground)	1
2	Tx2n	Transmitter Inverted Data Input	
3	Tx2p	Transmitter Non-Inverted Data output	
4	GND	Transmitter Ground (Common with Receiver Ground)	1
5	Tx4n	Transmitter Inverted Data Input	
6	Tx4p	Transmitter Non-Inverted Data output	
7	GND	Transmitter Ground (Common with Receiver Ground)	1
8	ModSelL	Module Select	
9	ResetL	Module Reset	
10	VccRx	3.3V Power Supply Receiver	2
11	SCL	2-Wire serial Interface Clock	
12	SDA	2-Wire serial Interface Data	
13	GND	Transmitter Ground (Common with Receiver Ground)	
14	Rx3p	Receiver Non-Inverted Data Output	
15	Rx3n	Receiver Inverted Data Output	
16	GND	Transmitter Ground (Common with Receiver Ground)	1
17	Rx1p	Receiver Non-Inverted Data Output	
18	Rx1n	Receiver Inverted Data Output	
19	GND	Transmitter Ground (Common with Receiver Ground)	1
20	GND	Transmitter Ground (Common with Receiver Ground)	1
21	Rx2n	Receiver Inverted Data Output	
22	Rx2p	Receiver Non-Inverted Data Output	
23	GND	Transmitter Ground (Common with Receiver Ground)	1
24	Rx4n	Receiver Inverted Data Output	1
25	Rx4p	Receiver Non-Inverted Data Output	
26	GND	Transmitter Ground (Common with Receiver Ground)	1
27	ModPrsl	Module Present	
28	IntL	Interrupt	
29	VccTx	3.3V power supply transmitter	2
30	Vcc1	3.3V power supply	2
31	LPMODE	Low Power Mode	
32	GND	Transmitter Ground (Common with Receiver Ground)	1
33	Tx3p	Transmitter Non-Inverted Data Input	
34	Tx3n	Transmitter Inverted Data Output	
35	GND	Transmitter Ground (Common with Receiver Ground)	1
36	Tx1p	Transmitter Non-Inverted Data Input	
37	Tx1n	Transmitter Inverted Data Output	
38	GND	Transmitter Ground (Common with Receiver Ground)	1

**Notes:**

1. GND is the symbol for signal and supply (power) common for QSFP28 modules. All are common within the QSFP28 module and all module voltages are referenced to this potential unless otherwise noted. Connect these directly to the host board signal common ground plane.
2. VccRx, Vcc1 and VccTx are the receiving and transmission power suppliers and shall be applied
3. concurrently. Recommended host board power supply filtering is shown below. Vcc Rx, Vcc1 and Vcc Tx

may be internally connected within the QSFP28 transceiver module in any combination. The connector pins are each rated for a maximum current of 500mA.

### VI. Host - Transceiver Interface Block Diagram

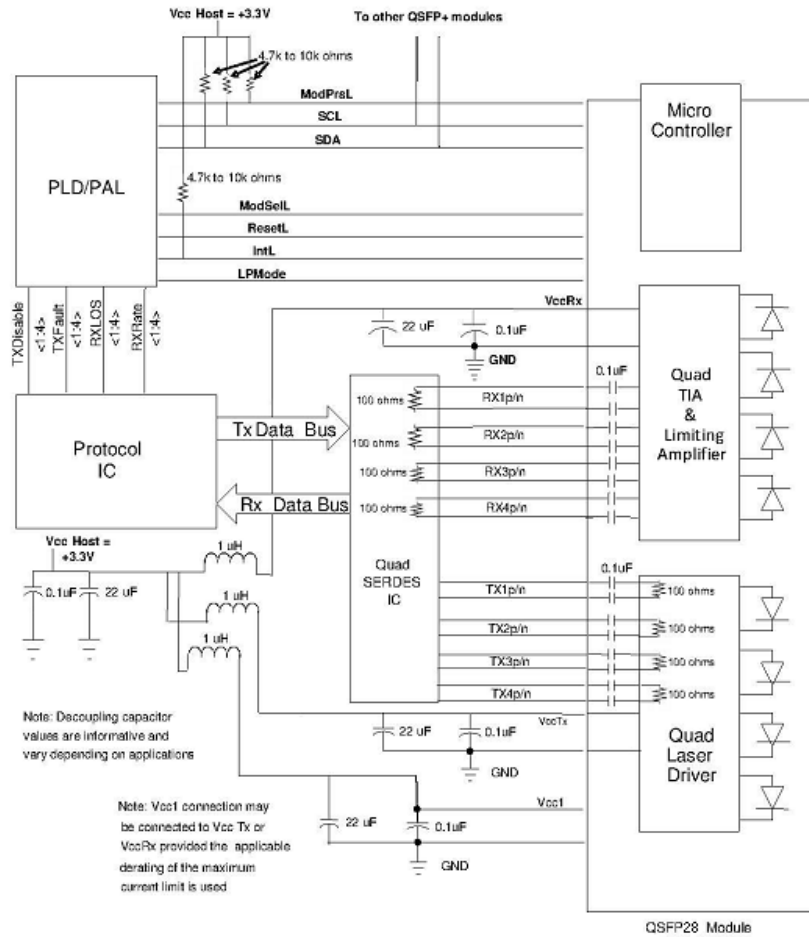

### VII. Ordering information

Part Number	Product Description
AE-QSFP28-LH4	QSFP28, 100Gb/s, 1295 -1310nm, SMF, 20KM, DDM, LC, 0°C ~ +70°C