

DWDM QSFP28 80km CS Connector Transceiver

P/N: AE-QSFP28-D80-XXXX

Features

- Hot pluggable QSFP28 MSA form factor
- Up to 80km reach for G.652 SMF with transport white box
- Single +3.3V power supply
- Temperature Range 0 to 70°C
- Transmitter: Cooled EML 2*27.5Gbaud/s DWDM TOSA
- Receiver: 2*27.5Gbaud/s SOP Pin ROSA
- 4*25G CAUI4 electrical interface
- Integrated SFEC with high coding gain
- PAM4 modulation format on 100GHz ITU DWDM wavelength grid compatible
- Dual CS adaptor
- Compatible with RoHS6

Applications

- High bandwidth connectivity for Data Center Interconnection
- 100G Ethernet Metro-Access over DWDM
- P to P Access Network

I. ABSOLUTE MAXIMUM RATINGS

Parameter	Symbol	Unit	Min	Max
Storage Temperature Range	T _s	°C	-40	+85
Relative Humidity	RH	%	5	85
Power Supply Voltage	V _{cc}	V	-0.5	+3.6
Operating Case Temperature Range	T _c	°C	0	+70
Receiver Damage Threshold Per Lane	P _{dag}	dBm	+5.2	

II. SPECIFICATION

Recommended Operating Conditions

Parameter	Units	MIN.	TYP.	MAX.	Notes
Recommended Operating Conditions					
Operating Case Temperature	°C	0		+70	
Power Supply Voltage	V	3.13 5	3.3	3.465	
Control Input Voltage High	V	2		V _{cc} +0.3	
Control Input Voltage Low	V	-0.3		0.8	
Rx Diff Data Output Load					
Power Dissipation	W		6		T _c = 70 °C, V _{cc} = 3.465V, End of Life

Electrical Characteristics

For electrical characteristics, refer to CAUI-4 chip-to-module draft specifications (IEEE P802.3bm Annex 83E). The CAUI-4 host output shall meet the specifications defined below while measured at TP1 for transmitter, TP4 for receiver.

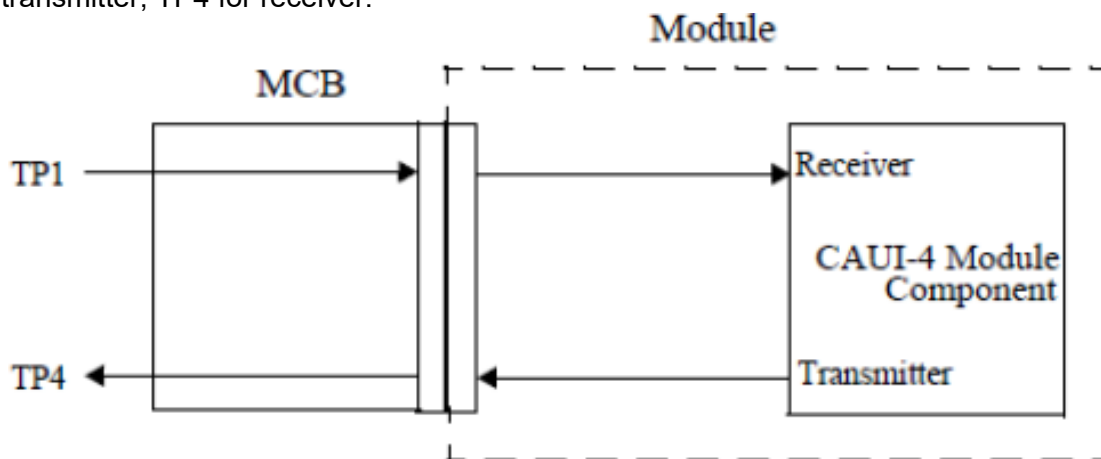

Figure 1: Module CAUI-4 compliance test point

III. Transmitter Electrical Specification (TP1)

Parameter	Comment	Min	Typ	Max	Unit
Signaling Rate, each lane		Typ -100 ppm	25.7813	Typ +100 ppm	Gb/s
DC Common Mode Output Voltage		-350	---	2850	mV
Differential Return Loss	See template1	---	---	---	dB
Common to Differential Mode Conversion Return Loss	See template2	---	---	---	dB
Differential Termination Mismatch	At 1 MHz	---	---	10	%

IV. Receiver Electrical Specification (TP4)

Parameter	Comment	Min	Typ	Max	Unit
Signaling Rate, each lane		Typ -100 ppm	25.7813	Typ +100 ppm	Gb/s
Common-Mode AC Output Voltage (RMS)		---	---	17.5	mV
Differential pk-pk output voltage swing		---	---	900	mVpp
Eye Width	EW15 at 10-15 probability; PRBS 29-1	0.57	---	---	UI
Eye Height Differential	EH15 at 10-15 probability; PRBS 29-1	228	---	---	mV
Vertical Eye Closure		---	---	5.5	dB
Differential Output Return Loss	See template1	---	---	---	dB
Common to Differential Mode Conversion Return Loss	See template2	---	---	---	dB
Differential Termination Mismatch		---	---	10	%
Transition Time (20% to 80%)		12	---	---	ps
DC Common Mode Voltage3		-350	---	2850	mV

Notes:

1. Reference IEEE P802.3bm Annex 83E, Figure 83E-7 for template
2. Reference IEEE P802.3bm Annex 83E, Figure 83E-8 for template

V. Transmitter Optical Specification (TP2)

Parameter	Units	MIN.	TYP.	MAX.	Notes
Optical output power	dBm	2		+6.5	
Transmitter Rate	Gbps		55.04318		55.04318*2λ
Lane center wavelength spacing	GHz		100		
Center wavelength	nm		See Wavelength Table		

Extinction ratio	dB		6		
Side-mode suppression Ratio	dB	30			
RIN OMA	dB/Hz			-132	
Optical Return Loss Tolerance	dB			20	
Transmitter reflectance	dB			-12	
Dispersion Tolerance	ps/nm	-150		50	Residual dispersion (RD) after DCM, and at worst ONSR

VI. Receiver Optical Specification(TP3)

Parameter	Units	MIN.	TYP.	MAX.	Notes
Receive Rate	Gbps		55.04318		55.04318*2λ
Center Wavelength	nm	See Wavelength Table			
Receiver reflectance	dB			-28	
Receiver Power, each lane	dBm	-12.5		6	
Required OSNR	dB	28			Receiving Power @0~-7dBm
		31			Receiving Power @-7~-12.5dBm
RSSI Accuracy	dB	-3		3	Pre-FEC BER 4E-3

VII. Wavelength Table:

TX1			TX2		
Ch. No.	Frequency (THz)	Center Wavelength(nm)	Ch. No.	Frequency (THz)	Center Wavelength(nm)
C13	191.30	1567.13	C14	191.40	1566.31
C13+	191.35	1566.72	C14+	191.45	1565.90
C15	191.50	1565.50	C16	191.60	1564.68
C15+	191.55	1565.09	C16+	191.65	1564.27
C17	191.70	1563.86	C18	191.80	1563.05
C17+	191.75	1563.45	C18+	191.85	1562.64
C19	191.90	1562.23	C20	192.00	1561.42
C19+	191.95	1561.83	C20+	192.05	1561.01
C21	192.10	1560.61	C22	192.20	1559.79
C21+	192.15	1560.20	C22+	192.25	1559.39
C23	192.30	1558.98	C24	192.40	1558.17
C23+	192.35	1558.58	C24+	192.45	1557.77
C25	192.50	1557.36	C26	192.60	1556.55
C25+	192.55	1556.96	C26+	192.65	1556.15

C27	192.70	1555.75	C28	192.80	1554.94
C27+	192.75	1555.34	C28+	192.85	1554.54
C29	192.90	1554.13	C30	193.00	1553.33
C29+	192.95	1553.73	C30+	193.05	1552.93
C31	193.10	1552.52	C32	193.20	1551.72
C31+	193.15	1552.12	C32+	193.25	1551.32
C33	193.30	1550.92	C34	193.40	1550.12
C33+	193.35	1550.52	C34+	193.45	1549.72
C35	193.50	1549.32	C36	193.60	1548.51
C35+	193.55	1548.91	C36+	193.65	1548.11
C37	193.70	1547.72	C38	193.80	1546.92
C37+	193.75	1547.32	C38+	193.85	1546.52
C39	193.90	1546.12	C40	194.00	1545.32
C39+	193.95	1545.72	C40+	194.05	1544.92
C41	194.10	1544.53	C42	194.20	1543.73
C41+	194.15	1544.13	C42+	194.25	1543.33
C43	194.30	1542.94	C44	194.40	1542.14
C43+	194.35	1542.54	C44+	194.45	1541.75
C45	194.50	1541.35	C46	194.60	1540.56
C45+	194.55	1540.95	C46+	194.65	1540.16
C47	194.70	1539.77	C48	194.80	1538.98
C47+	194.75	1539.37	C48+	194.85	1538.58
C49	194.90	1538.19	C50	195.00	1537.40
C49+	194.95	1537.79	C50+	195.05	1537.00
C51	195.10	1536.61	C52	195.20	1535.82
C51+	195.15	1536.22	C52+	195.25	1535.43
C53	195.30	1535.04	C54	195.40	1534.25
C53+	195.35	1534.64	C54+	195.45	1533.86
C55	195.50	1533.47	C56	195.60	1532.68
C55+	195.55	1533.07	C56+	195.65	1532.29
C57	195.70	1531.90	C58	195.80	1531.12
C57+	195.75	1531.51	C58+	195.85	1530.72
C59	195.90	1530.33	C60	196.00	1529.55
C59+	195.95	1529.94	C60+	196.05	1529.16

Notes:

The two channels of the transceiver meet above wavelength table. And other channel wavelength configurations are acceptable for customize design.

All the specification is designed by single wavelength.

VIII. 3. Electric Ports Definition

NO	PIN	DEFINITION	DESCRIPTION	NOTE
1	1	GND	Ground	1
2	2	Tx2n	Transmitter Inverted Data Input	
3	3	Tx2p	Transmitter Non-Inverted Data Input	
4	4	GND	Ground	1

5	5	Tx4n	Transmitter Inverted Data Input	
6	6	Tx4p	Transmitter Non-Inverted Data Input	
7	7	GND	Ground	1
8	8	ModSelL	Module Select	
9	9	ResetL	Module Reset	
10	10	VccRx	+3.3V Power Supply Receiver	2
11	11	SCL	2-Wire Serial Interface Clock	
12	12	SDA	2-Wire Serial Interface Data	
13	13	GND	Ground	1
14	14	Rx3p	Receiver Non-Inverted Data Output	
15	15	Rx3n	Receiver Inverted Data Output	
16	16	GND	Ground	1
17	17	Rx1p	Receiver Non-Inverted Data Output	
18	18	Rx1n	Receiver Inverted Data Output	
19	19	GND	Ground	1
20	20	GND	Ground	1
21	21	Rx2n	Receiver Inverted Data Output	
22	22	Rx2p	Receiver Non-Inverted Data Output	
23	23	GND	Ground	1
24	24	Rx4n	Receiver Inverted Data Output	
25	25	Rx4p	Receiver Non-Inverted Data Output	
26	26	GND	Ground	1
27	27	ModPrsL	Module Present	
28	28	IntL	Interrupt	
29	29	VccTx	+3.3 V Power Supply transmitter	2
30	30	Vcc1	+3.3 V Power Supply	2
31	31	LPMode	Low Power Mode	
32	32	GND	Ground	1
33	33	Tx3p	Transmitter Non-Inverted Data Input	
34	34	Tx3n	Transmitter Inverted Data Input	
35	35	GND	Ground	1
36	36	Tx1p	Transmitter Non-Inverted Data Input	
37	37	Tx1n	Transmitter Inverted Data Input	
38	38	GND	Ground	1

NOTE:

1. GND is the symbol for signal and supply (power) common for the QSFP28 module. All are common within the module and all module voltages are referenced to this potential unless otherwise noted. Connect these directly to the host board signal common ground plane.

2. VccRx, Vcc1 and VccTx are the receiving and transmission power suppliers and shall be applied concurrently. Recommended host board power supply filtering is shown in Figure 3 below. Vcc Rx, Vcc1 and VccTx may be internally connected within the module in any combination. The connector pins are each rated for a maximum current of 2000mA.

IX. 4. SFF-8636

SFF-8636 defines a common management interface for 4-lane pluggable transceiver modules,

direct attach modules and shielded cable assemblies. It sets the EEPROM memory space as follows:

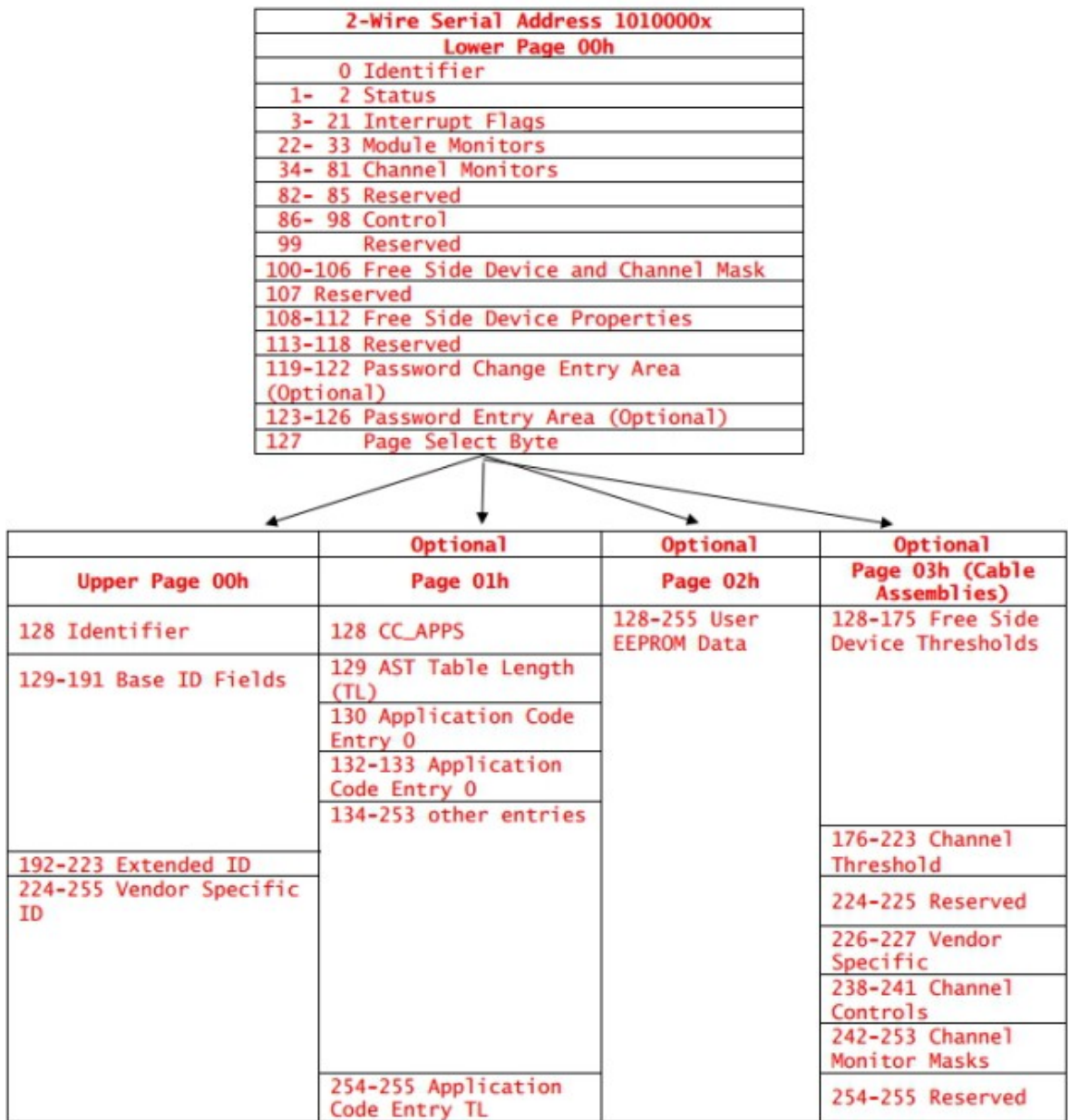

X. 5. DDM

DDM accuracy:

Parameters	Unit	Requirements	Note
temperature	°C	+/-3	
voltage	V	+/-5%	
Ibias	mA	+/-10%	
Rx power	dB	+/-3.0	
Tx power	dB	+/-3.0	

DDM Alarm & warning threshold is listed below:

Parameters	Unit	Requirements	Description
Temp low warning	°C	0	Min. case temperature
Temp high warning	°C	70	Max. case temperature
Voltage low warning	V	3.135	-5% Vcc target
Voltage high warning	V	3.465	+5% Vcc target
Tx power low warning	dBm	-1	Min. optical power in DS.
Tx power high warning	dBm	4	Max. optical power in DS.
Rx power low warning	dBm	-12.5	Sensitivity
Rx power high warning	dBm	4.2	Overload
Temp low alarm	°C	-10	Warning-10°C
Temp high alarm	°C	+80	Warning+10°C
Voltage low alarm	V	2.97	-10% Vcc target
Voltage high alarm	V	3.63	+10% Vcc target
Tx power low alarm	dBm	-4	Warning -3dB
Tx power high alarm	dBm	7	Warning +3dB
Rx power low alarm	dBm	-15.5	Warning -3dB
Rx power high alarm	dBm	7.2	Warning +3dB

XI. 6. Recommended Power Supply Filter

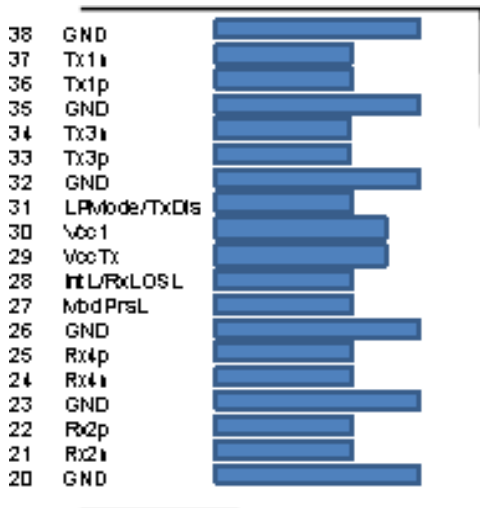
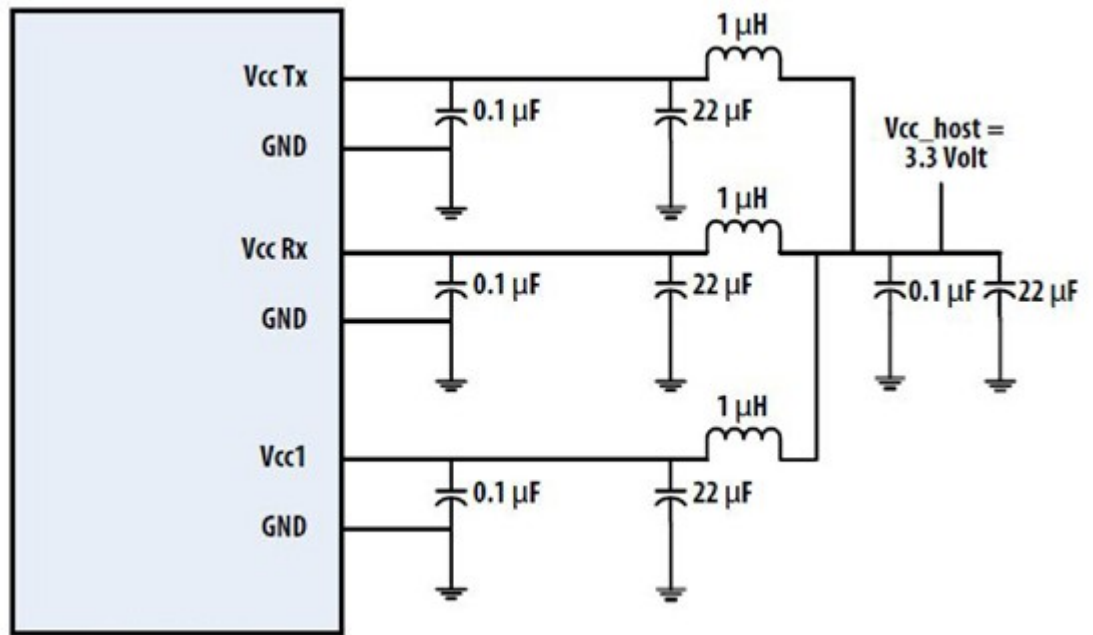

Top Side
Viewed From Top

Module Card Edge

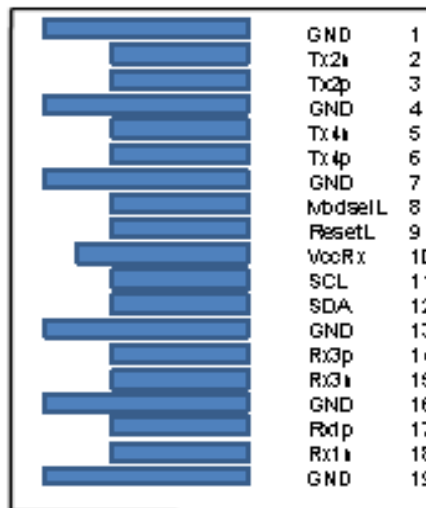

Bottom Side
Viewed From Bottom

8. ESD

This transceiver is specified as ESD threshold 1kV for SFI pins and 2kV for all other electrical input pins, tested per MIL-STD-883, Method 3015.4 /JESD22-A114-A (HBM). However, normal ESD precautions are still required during the handling of this module. This transceiver is shipped in ESD protective packaging. It should be removed from the packaging and handled only in an ESD protected Environment.

9. Ordering information

Part No	Specifications						
	Package	Data rate	Tx	Pout	Rx Sen.	Top	Others
AE-QSFP28-D80-XXXX	QSFP28	103.125 Gbps	Cooled EAM EML-LD	-1 ~ +4 dBm	-28dBm @BER 5E-5	0~70°C	DDM